

activTek®

ENVIRONMENTAL

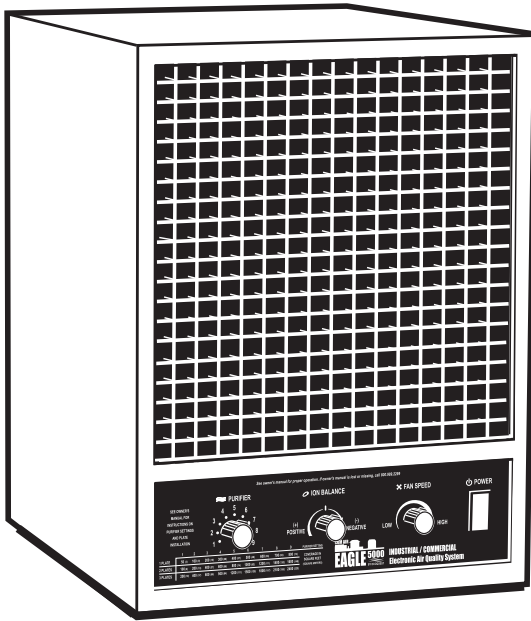

**EAGLE
5000**

Electronic Air Purification System

100, 120, 220, and 240 Volt Systems

READ MANUAL CAREFULLY FOR PROPER PROCEDURES AND OPERATION.
DOES NOT MEET CALIFORNIA REQUIREMENTS; CANNOT BE SHIPPED TO CALIFORNIA.



CONTENTS

Specifications	3
Introduction.....	4
Features.....	4
Applications.....	4
Installation.....	5
Lint Screen & Carbon Filter Removal	6
Purification Plate Installation	7
Carbon Filter Installation	8
Lint Screen Installation	8
Placing the Unit	9
Settings and Adjustments	10
Maintenance	11
Changing the Fuse	12
Troubleshooting	12
Warranty Information	14

Please record the name and phone of your activTek Dealer:

Name _____

Phone _____

Please record the serial number of your Eagle 5000:

Serial # _____

Features:

- Positive/Negative Ion Generation Technology.
- Adjustable Ozone Generation.
- Activated Charcoal Deodorization.
- Adjustable fan speed control.
- Washable permanent lint screen.
- Adjustable ozone control and plate configuration.
- Adjustable ion control.

Electrical:

- 100 volt 50/60hz, 120 volt 60hz, 230 volt 50/60 hz, or 240 volt 50 hz.
- Less than 60 watts power consumption.
- 24 to 30 KV, 20-30 khz ion generation pulsator.
- 20 KV negative ion generator.

Mechanical:

- 82 CFM

Size:

- Dimensions: 15.5" high x 12" wide x 12.75" deep
- Weight: 35 pounds

Ozone Output:

- 140-430 mg per hour (depending on the number of plates installed)



CAUTION: To reduce the risk of electric shock, this equipment has a grounding type plug that has a third (grounding) pin. This plug will only fit into a grounding type power outlet. If the plug does not fit into the outlet, contact qualified personnel to install the proper outlet. Do not alter the plug in any way.



WARNING: Do not operate this unit without one or all purification plate(s) properly installed. Doing so may void the warranty.



CAUTION: Disconnect power cord before servicing.
100 and 120 volt models - use 1.6 Amp slow blow fuse.
220 and 240 volt models - use 0.5 Amp slow blow fuse.



Location for Protective Earth Line.

INTRODUCTION

Nature cleanses the air with lightning and rain. Lightning bolts produce ozone, as well as positive and negative ions, which cleanse the air naturally. Rain helps bring the ozone and ions closer to the earth's surface. They are then attracted to atmospheric contaminants that are either removed from the air and attached to grounded objects or are oxidized.

The Eagle 5000 reproduces the natural conditions found in the outdoors. It is not designed to create an artificial environment. The reestablishment of a natural environment takes place out in the air, rather than inside the unit. It cleanses the air, rather than filtering it, masking the symptoms, or attempting to dilute it.

FEATURES

- Compact
- Portable
- No Ductwork Required
- No Chemicals
- Low Maintenance
- Low Electrical Usage
- Complete User Control
- No Residual Contamination

APPLICATIONS

- Restaurants
- Smoking Areas
- Produce Areas
- Basements
- Veterinary Offices
- Casinos
- Large Meeting Halls
- Kennels
- Stables & Barns
- Photo Labs
- Salons
- Day Care Centers
- Chemical Odors
- Bowling Alleys
- Bingo Parlors

INSTALLATION

1. Remove unit from shipping carton.
2. Remove all protective materials.
3. Check for shipping damage and loose or broken parts.
4. Read owner's manual thoroughly prior to installation.
5. Remove purification plates from the box and install (page 7).
6. Install the internal carbon filter (page 8).
7. Install the rear lint screen (bottom of page 8).
8. Fully insert cord into the power cord receptacle on the back of the unit.
9. Determine placement location for the unit (page 9), plug the unit into a 100 volt, 120 volt, 220 volt, or 240 volt (depending on model) outlet, be sure the power switch is on, and adjust controls according to the application.

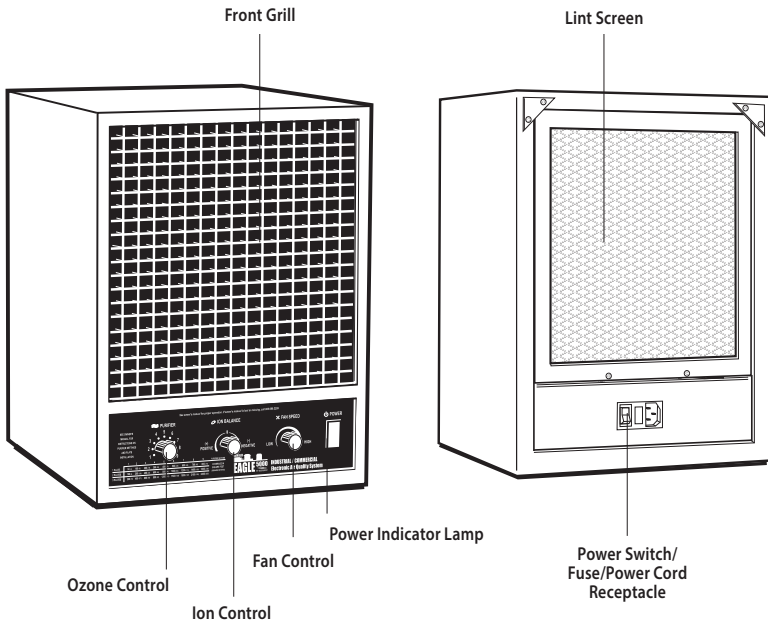

LINT SCREEN & CARBON FILTER REMOVAL

1. Unplug the Eagle 5000 to prevent electric shock.

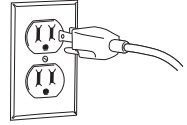

2. Remove only one screw from each of the 2 top corner brackets and rotate bracket out of the way.

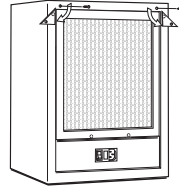

3. Remove 2 screws from bottom of lint screen.

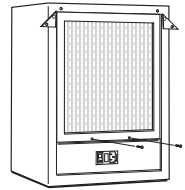

4. Pull top of lint screen toward you, then lift out.

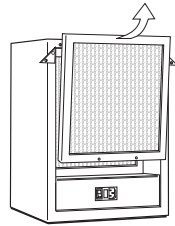

5. Once the lint screen is removed, the carbon filter may be removed also.

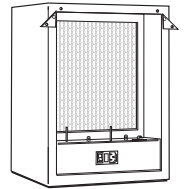

6. Using the plastic tab, pull the top of the carbon filter towards you.

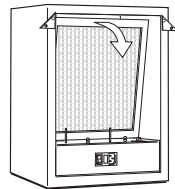

7. Pull the carbon filter out of the unit.

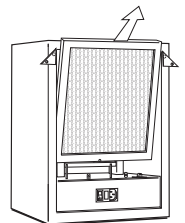

PURIFICATION PLATE INSTALLATION

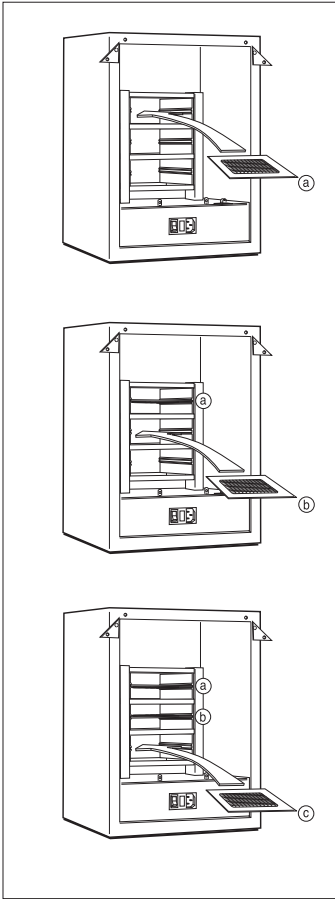

1. Remove the rear lint screen and the internal carbon filter (see page 6).
2. After determining the square footage (use the formula $\text{SQUARE FEET} = \text{LENGTH} \times \text{WIDTH}$) use the Purifier Setting chart (below or on the faceplate of the unit) to determine the correct number of plates to install.
3. Fully insert the needed purification plates (a,b,c) between the guide-grooves in the sides of the plate cage (between the posts and clips) making sure the metal clip on each side of the plate is in contact with the metal screen on the plate.
4. Replace the carbon filter and reinstall the rear lint screen (page 8).

	1	2	3	4	5	6	7	8	9	PURIFIER SETTING
1 PLATE	50 (4)	100 (9)	200 (10)	300 (28)	400 (37)	500 (46)	600 (56)	700 (65)	800 (74)	COVERAGE IN SQUARE FEET (SQUARE METERS)
2 PLATES	100 (9)	200 (19)	400 (37)	600 (56)	800 (74)	1000 (93)	1200 (111)	1400 (130)	1600 (149)	
3 PLATES	200 (19)	400 (37)	600 (56)	900 (84)	1200 (111)	1500 (139)	1800 (167)	2100 (195)	2400 (223)	

*Chart refers to heavily contaminated areas

CARBON FILTER INSTALLATION

1. Always install carbon filter bottom first.
2. Once the bottom of the filter is in place, insert the top of the filter into the case.
3. When properly installed, the carbon filter fits against the internal stops located on the left and right insides of the case.

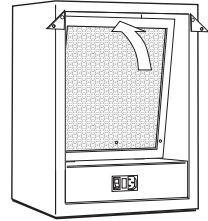
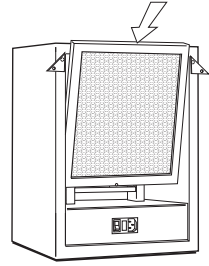
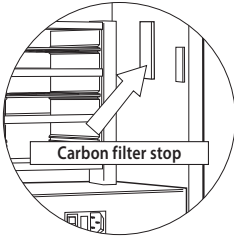

LINT SCREEN INSTALLATION

1. Always install lint screen bottom first.
2. The bottom of the lint screen should depress the safety switch arm towards the bottom of unit.

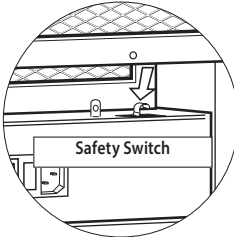

3. Insert 2 screws at bottom of lint screen (do not overtighten screws).
4. Fit top of lint screen into cabinet, rotate 2 corner brackets and secure with screws.

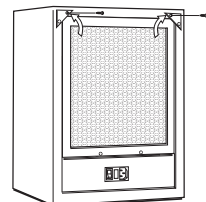
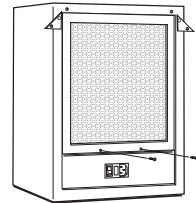
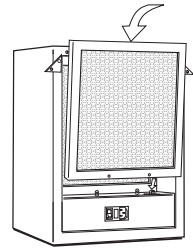

PLACING THE UNIT

Place the unit as high as possible (5-6 feet min) to ensure complete purification. Do not turn the unit directly towards a wall or the ceiling.

If raised placement is not available, place unit as high as possible and elevate the front of unit. Some pollutants such as smoke will rise and the unit, when elevated, can oxidize the pollutants more effectively. A ceiling fan can also aid in distribution of cleansing properties.

The Eagle 5000 is most effective when placed in a position that allows the ions and ozone to be mixed evenly and thoroughly with the polluted air.

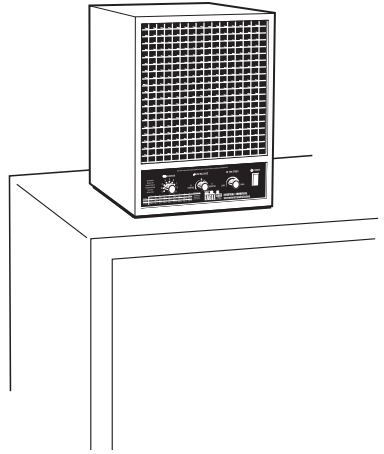

Suggested locations, listed in the order of preference:

1. Nearest the source of the worst pollution.
2. Near a cold air return to thoroughly circulate clean air throughout the area.
3. In the area most heavily used to achieve maximum benefit.

NOTE:

- For maximum control, the unit should be placed where easy access to the controls is possible.
- The rear of the unit should always have at least one inch of open area to allow unrestricted airflow.
- Be sure power cord is not accessible to small children to prevent injury.



CAUTION: This unit should never be placed where it can blow directly into the face of any person or pet.

SETTINGS AND ADJUSTMENTS

1. FAN CONTROL

The disbursement of cleansing properties is best accomplished with good air circulation. The fan control should be set as high as reasonably possible without creating an undesirable noise level. This will be determined by personal preference and the distance you wish the cleansing properties to be dispersed.

NOTE: A ceiling fan can also aid in distribution of cleansing properties.

2. PURIFIER CONTROL

PURIFIER Control: Set the control at the nine o'clock position for one hour.

Adjust the control up or down after one hour based on the following criteria:

1. In normal conditions, it is not necessary to turn the PURIFIER control indicator above the area of the environment. (refer to purifier chart on page 7)
2. Keeping in mind the previous statement (#1), adjust the purifier so that the scent of ozone fades into the background 15-30 seconds after entering the environment.

3. AWAY MODE FEATURE

For maximum effectiveness in reducing air contaminants, turn the unit on high for 3-4 hours.



CAUTION: Always be sure a room or area is UNOCCUPIED before performing the above described Away Mode procedure.

Air out room by opening doors and/or windows.

4. ION CONTROL

The normal setting of a DC ionizer is full negative. This setting seems to work best in removing particulate (cigarette smoke) as well as reducing static. When trying to reduce static, if the full negative setting results in more static, turn the ion control in small increments towards the positive until the static is relieved.

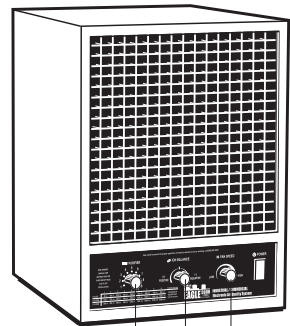

Purifier Control

Fan Control

Ion Control

MAINTENANCE

Periodic maintenance is required to ensure that the Eagle 5000 operates properly. A severely polluted environment can foul a purification plate in as little as two weeks or as long as a year. Shown here are basic maintenance procedures that should be carried out to keep your unit running at top performance.

Rear lint screen/carbon filter cleaning (see page 6 for removal instructions):

You have two options to clean the lint screen and carbon filter:

- When visibly dirty, simply remove the lint screen or carbon filter. With a hand-held vacuum, remove the heavy particulate from the screen. This method will extend the life of the screen/filter.
- OR -
- When visibly dirty, remove the lint screen or carbon filter from the unit. Wash in hot water, brushing gently with a toothbrush to remove particulate. Allow to dry completely prior to reinstalling the lint screen.

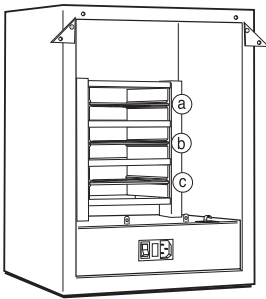

PURIFICATION PLATE

Remove the rear lint screen (page 6).

Carefully remove the purification plates (a, b, c).

Clean the plates (a, b, c) with equal parts hot water and ammonia. Dry completely using a hair dryer if necessary. Reinstall plates (page 7). Be sure to check that the electrical tabs are in contact with the plate.

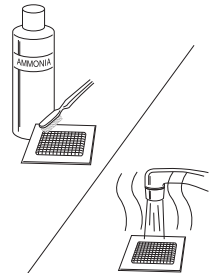
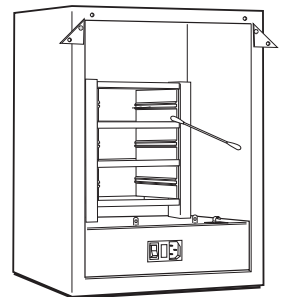

PLATE CARD CAGE

Also be sure to clean the stand-offs at the corners of the plate card cage (A cotton swab with alcohol works well).

FAN BLADE AND FRONT GRILL

Wipe off fan blade and front grill (if dirty) with a damp washcloth. The fan requires no maintenance (with the exception of the first time it is used, when it may be necessary to give it a gentle push to get it started). If the fan squeaks, a drop of lightweight oil may be needed on the fan shaft.



CHANGING THE FUSE

A fuse holder is located on the back of the unit next to the power cord. To replace or check the fuse, remove the fuse holder by pressing on the release catches and pulling straight out.

If the fuse is blown, replace with a new slow blow fuse. Insert the new fuse into the fuse holder. Press the assembly in until it latches.

If the fuse holder cap is not installed correctly, the unit will not operate.

100 and 120 Volt Use 1.6 AMP slow blow fuse.
220 and 240 Volt Use 0.5 AMP slow blow fuse.

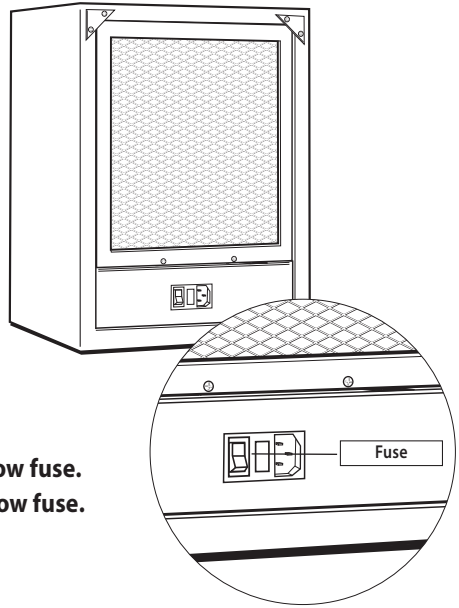

TROUBLESHOOTING

INDICATORS OF OPERATION

Operation of the ion indicator lamp:

Turn the unit on and check that the small red/orange lamp is illuminated. The lamp is located inside the unit and is viewed by looking into the unit through the front grill. Illumination of the internal lamp verifies that the frequency type ionizer is functioning properly. The lamp should stay illuminated as long as the unit is turned on.

TROUBLESHOOTING - WHAT TO LOOK FOR FIRST.

1. *I have plugged in the unit, turned "ON" the power switch and nothing happens... what's wrong?*
 - Make sure the electrical outlet is capable of providing power to the unit.
 - Check the lint screen located at the back of the machine to ensure that the safety switch activator clip depresses the safety switch.
 - Check to see if the proper fuse is installed and that it is serviceable.
 - Ensure that the fuse cap is completely seated and secured in its receptacle.
 - Be sure the cord is fully plugged into unit.
2. *The fan is operating although the unit won't produce any ozone... what's wrong?*
 - Check the purification plate(s) for serviceability. If they are cracked or broken, the plate(s) will require replacement. Ensure maintenance procedures required for the purification plate(s) have been performed according to the "Maintenance" section (page 11) of this owner's manual. Order new plates from your Ativtek Dealer.
 - Electrical stainless steel contacts are not contacting the screen portion of the purification plate(s). Inspect the unit for any loose connections.
 - Do not attempt to disassemble the unit, due to the Limited Warranty of the product.
3. *How am I able to know if the Frequency-Type Ionizer is working?*
 - Current models with the FT Ionizer system have a neon light bulb mounted on the base of the FT antenna. When the power switch to the unit is turned ON, the neon light bulb will illuminate, indicating that the FT Ionizer is functioning normally (see above, "Indicators of Operation").
4. *The purification plate(s) are making a noise, have a burning smell, and/or appear to arc or spark. What is the problem?*
 - Purification plate is most likely cracked. Refer to the answers for question #2, as it would apply to this question also.

TROUBLESHOOTING (CONTINUED)

5. **What are the most typical application problems?**
- **Symptom:** A belief that the proper equipment is placed in the environment and the equipment appears unsuccessful.
 - **Problem:** Lack of air movement, improper placement of the unit.
 - **Symptom:** Strong odors still remain with the environment after placement.
 - **Problem:** Lack of ozone, improper placement of the unit.
 - **Symptom:** A strong odor of ozone is present within the environment.
 - **Problem:** Too much ozone accumulation within the environment, as a result of improper purifier control setting, and/or lack of air movement.
 - **Symptom:** Visual haze of smoke and/or particulate remain within the environment.
 - **Problem:** Lack of ionization and/or air movement.
6. **Unit does not operate.**
- Is the unit plugged in?
 - Is the power cord fully inserted into the back of the unit?
 - Are you sure the outlet is active?
 - Is the unit turned on?
 - Is the rear lint screen installed properly to depress the safety switch forward?
7. **Air flow is restricted or reduced.**
- Is the unit properly placed away from objects that may obstruct air flow?
 - Are the filter and fan housing clean?

If your unit fails to operate properly after performing troubleshooting, contact your ActivTek Dealer for further assistance, contact us at the address located on the front of the manual, or visit www.activTek.net for additional technical support.

LIMITED 3 YEAR WARRANTY

For warranty service, please contact *activTek Customer Service* or your *Independent Business Owner* for the address of the nearest service center.

WHAT IS COVERED BY THIS WARRANTY

We warrant the Eagle 5000 (excluding filters) to the consumer, subject to the conditions below, against defects in workmanship or material, provided that the products are returned to a service location within the following time periods:

- Eagle 5000 within three (3) years of date of purchase.

INSTALLATION AND MAINTENANCE REQUIREMENTS

This warranty is expressly condition upon proper installation, usage and maintenance, all in accordance with the Owner's Manual. (i) the Eagle 5000 must be installed in accordance with the Owner's Manual; (ii) the Eagle 5000 must be used and maintained in accordance with the Owner's Manual. Failure to meet any of these requirements will void this warranty. Servicing of your Eagle 5000 by parties other than our authorized representative and/or using parts other than genuine parts will also void this warranty.

HOW TO OBTAIN WARRANTY SERVICE

Customer must contact our Independent Business Owner and provide proof of purchase within the above time periods. We will repair or replace and return the product, without charge and within a reasonable period of time, subject to the conditions in the above paragraphs, if its examination shall disclose any part to be defective in workmanship or material. If we, in our discretion, are unable to repair the product after a reasonable number of attempts, we will provide either a refund of the purchase price or a replacement unit, at the company's option.

WHAT IS NOT COVERED BY THIS WARRANTY

This product is intended for household use only and only for use with municipal water systems. Ordinary wear and tear shall not be considered a defect in workmanship or material. These warranties do not apply to filters nor for loss or damage caused by accident, fire, abuse, misuse, improper installation, leaking, modification, misapplication, commercial use, or by any repairs other than those provided by our authorized Service Center. This warranty does not cover any water damage.

MISSING SERIAL NUMBERS AND UNAUTHORIZED CHANNELS

If a valid serial number is missing from the product, the warranty will be voided. *activTek* products are authorized for sale through *activTek* Distributors only. Warranties are voided if a product is purchased through unauthorized channels; this includes websites that are not authorized to use *activTek*'s trademarked names, images and logos as well as Internet auction sites (e.g. eBay and craigslist). The only approved Internet presence for *activTek* products is www.activTek.net. To confirm warranty coverage prior to purchasing a product, contact *activTek* at 866-736-0503 with the serial number located on the back of the unit.

EXCLUSION OF OTHER WARRANTIES AND CONDITIONS

EXCEPT AS PROVIDED HEREIN, WE MAKE NO REPRESENTATION OR WARRANTY OF ANY KIND. ALL OTHER WARRANTIES OF ANY KIND, EXPRESS OR IMPLIED, ARE HEREBY EXPRESSLY DISCLAIMED, INCLUDING ANY IMPLIED WARRANTY OF MERCHANTABILITY OR FITNESS FOR A PARTICULAR PURPOSE.

LIMITATION OF LIABILITY FOR SPECIAL, INCIDENTAL, OR CONSEQUENTIAL DAMAGES

WE SHALL NOT IN ANY CASE BE LIABLE FOR SPECIAL, INCIDENTAL OR CONSEQUENTIAL DAMAGES ARISING FROM BREACH OF EXPRESSED OR IMPLIED WARRANTIES, CONDITIONS, GUARANTEES OR REPRESENTATIONS, BREACH OF CONTRACT, NEGLIGENCE OR ANY OTHER LEGAL THEORY. Such excluded damages include, but are not limited to, loss of profits or revenue, and loss of the use of the products.

FOR U.S. APPLICATION ONLY

This warranty gives you specific legal rights, and you may also have other rights which vary from state to state. Some states do not allow limitations on warranties, or on remedies for breach. In such states, the above limitations may not apply to you.

FOR CANADIAN APPLICATION ONLY

Exclusion of Subsequent Owners: Except as otherwise required by applicable legislation, this warranty is not transferable. This warranty gives you specific legal rights and you may also have other rights which vary from province to province. Some provinces and territories do not allow limitations on warranties, or on remedies for breach. In such provinces or territories, the above limitations may not apply to you. If any provision of this warranty or part thereof is held by a court of competent jurisdiction to be invalid, illegal, or unenforceable, the validity, legality and enforceability of the remaining provisions or parts thereof will not in any way be affected or impaired within the jurisdiction of that court. This entire warranty shall continue to be valid, legal and enforceable in any jurisdiction where a similar determination has not been made.

This warranty is provided by:

DBG Group Investments, LLC
dba *activTek* Environmental
300 East Valley Drive
Bristol, VA 24201

SERVICE

Every effort is made to ensure customers receive an up-to-date instructions manual on the use of our products; however, from time to time, modifications to our products may without notice make the information contained herein subject to alteration. For the latest information, please visit our web site.

This equipment has been tested and found to comply with the limits for Industrial, Scientific, and Medical Equipment (ISM), pursuant to Part 18 of the FCC Rules. These limits are designed to provide reasonable protection against harmful interference in a residential installation. This equipment generates, uses, and can radiate radio frequency energy and, if not installed and used in accordance with the instructions, may cause harmful interference to radio communications. However, there is no guarantee that interference will not occur in a particular installation. If this equipment does cause harmful interference to radio or television, which can be determined by turning the equipment off and on, the user is encouraged to try to correct the interference by one or more of the following measures:

Reorient or relocate the receiving antenna.

Increase the separation between the equipment and receiver.

Connect the equipment into an outlet on a circuit different from that to which the receiver is connected.

Consult the Dealer or an experienced radio/TV technician for help.

FCC DECLARATION OF CONFORMITY

Name: DBG Group Investments, LLC
dba activTek Environmental

Model: Eagle 5000

This device complies with Part 18 of the FCC Rules.

RESPONSIBLE PARTY

DBG Group Investments, LLC
dba activTek Environmental
300 East Valley Drive
Bristol, VA 24201

Ph: (866) 736-0503

Signature: 

Printed Name: Andy Eide

Title: Vice President, Product
Development and Research

Date: 10/11/18

CE DECLARATION OF CONFORMITY

We, on behalf of:

DBG Group Investments, LLC
dba activTek Environmental
300 East Valley Drive
Bristol, VA 24201
U.S.A.

activTek 
ENVIRONMENTAL

Declare under our sole responsibility, that the Electronic Air Purification System

Model: Eagle 5000

to which this declaration relates, conforms with the following standards:

EN55014-1	EMC Requirements for Household Appliances and Similar Apparatus - Emissions
EN55014-2	EMC Requirements for Household Appliances and Similar Apparatus - Immunity
EN60335-1:2002	Safety of Household and Similar Electrical Appliances - General Requirements
EN60335-2-65:2003	Safety of Household and Similar Electrical Appliances - Air Cleaning Appliances

By conformance with the standards referenced, the product meets the provisions of the EU Directives listed below:

Low Voltage Directive	2006/95/EC
EMC Directive	89/336/EEC as amended by 92/31/EED and 93/68/EEC
RoHS Directive	2002/95/EC
WEEE Directive	2002/96/EC

Authorized by: 

Representative: Andy Eide

Title: Vice President, Product Development and Research

Company: DBG Group Investments, LLC
dba activTek Environmental
300 East Valley Drive
Bristol, VA 24201
U.S.A.

Date: 10/11/18